

ROTARY VALVE

HYGIENIC SERIES

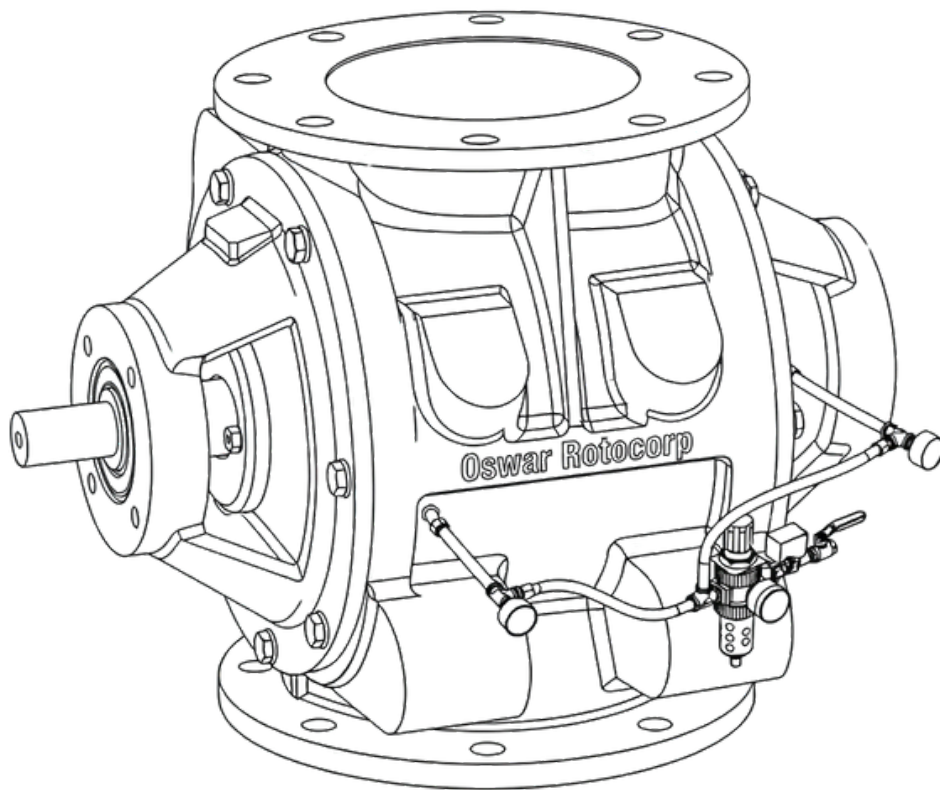

OSWAR
rotocorp

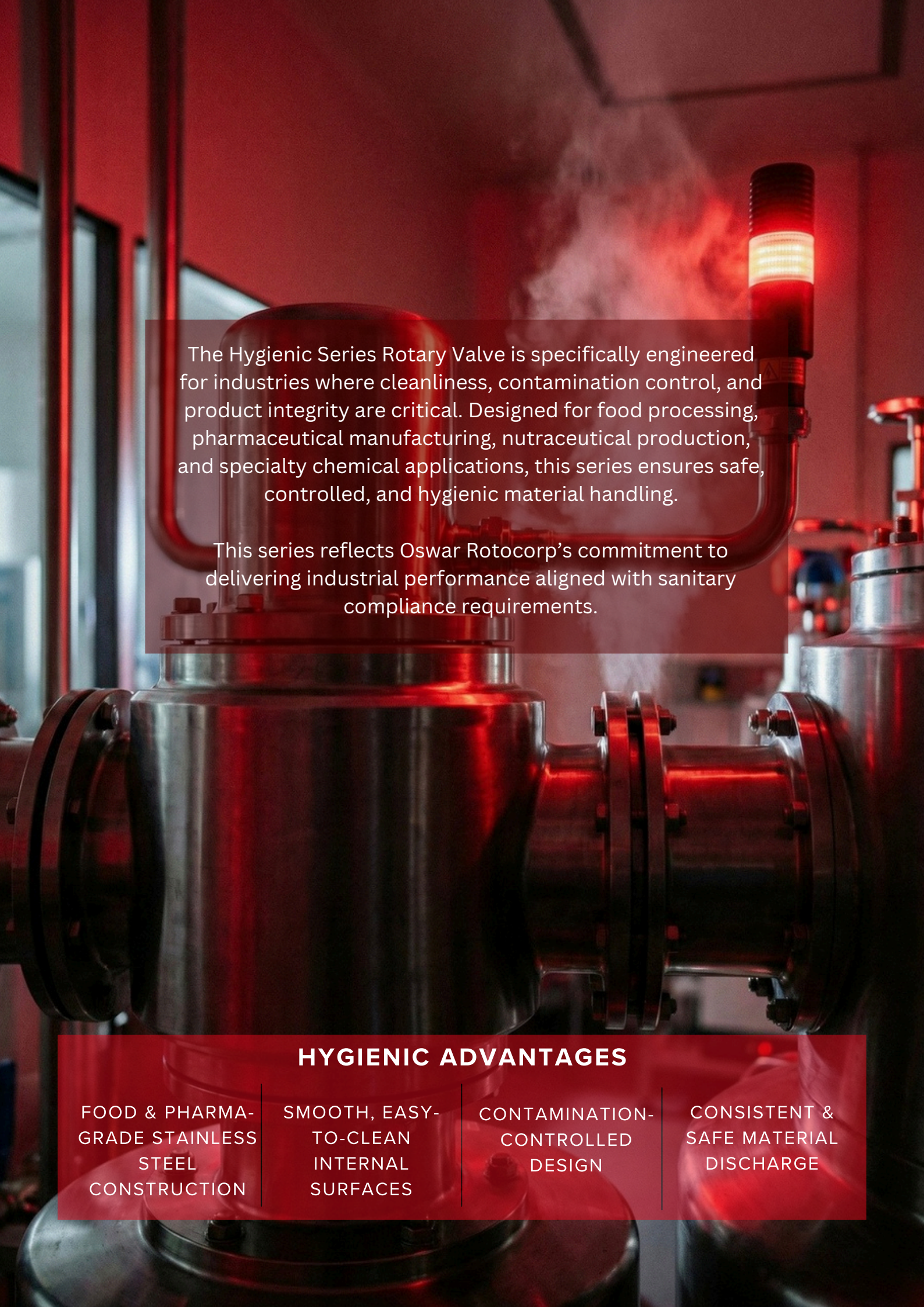

The Hygienic Series Rotary Valve is specifically engineered for industries where cleanliness, contamination control, and product integrity are critical. Designed for food processing, pharmaceutical manufacturing, nutraceutical production, and specialty chemical applications, this series ensures safe, controlled, and hygienic material handling.

This series reflects Oswar Rotocorp's commitment to delivering industrial performance aligned with sanitary compliance requirements.

HYGIENIC ADVANTAGES

FOOD & PHARMA-
GRADE STAINLESS
STEEL
CONSTRUCTION

SMOOTH, EASY-
TO-CLEAN
INTERNAL
SURFACES

CONTAMINATION-
CONTROLLED
DESIGN

CONSISTENT &
SAFE MATERIAL
DISCHARGE

ENGINEERED FOR CLEANLINESS & PRODUCT INTEGRITY

The Hygienic Series Rotary Valve is constructed with precision-machined stainless steel housings and polished internal surfaces to reduce residue accumulation and facilitate thorough cleaning. Rotor geometry is optimized to ensure gentle handling of powders and granular materials while maintaining volumetric accuracy. Sealing systems are designed to prevent cross-contamination and maintain airlock efficiency without compromising hygienic integrity.

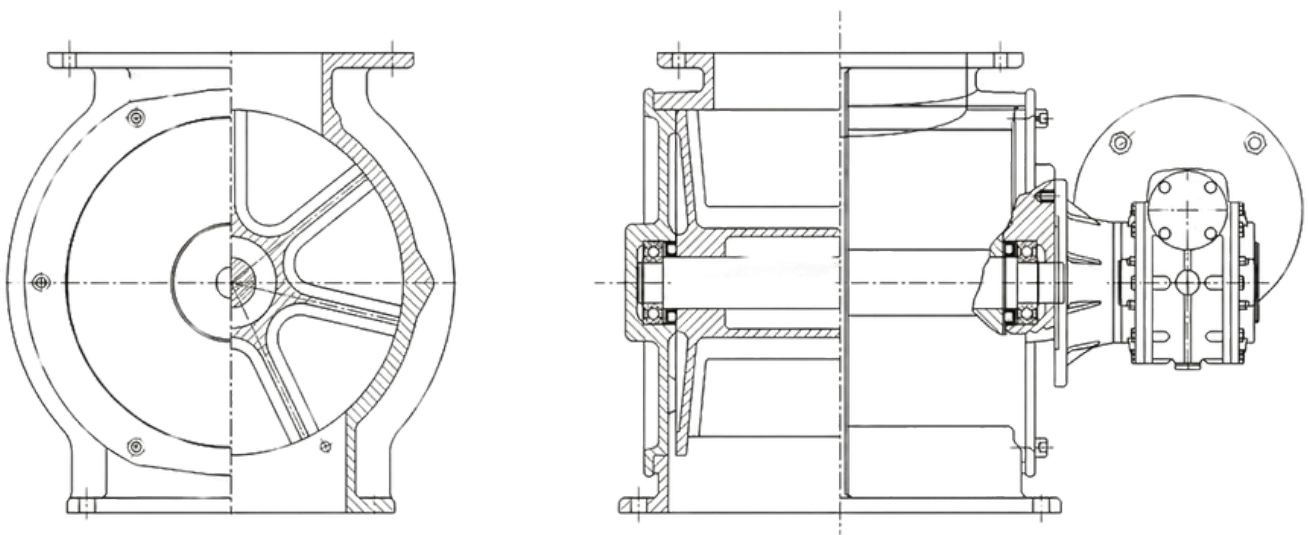

ENGINEERING FEATURES

- Stainless steel body (food/pharma grade)
- Polished and smooth internal finish
- Hygienic rotor design for uniform flow
- Contamination-resistant sealing system
- Quick-access maintenance design

APPLICATIONS IN HYGIENIC INDUSTRIES

Typical Applications:

- **Food Powder Handling**
- **Flour & Grain Processing**
- **Dairy Powder Systems**
- **Pharmaceutical Powder Transfer**
- **Nutraceutical & Specialty Chemical Feeding**

Industries Served:

- **Food Processing**
- **Pharmaceutical Manufacturing**
- **Nutraceutical Production**
- **Specialty Chemical Industries**
- **Agro & Animal Feed Processing**



OSWAR

rotocorp

Corporate Office

Jaipur, Rajasthan India
Nagpur, Maharashtra India

Sales Inquiries

info@oswarrotocorp.com

Helpline

[+44 7917 128505](tel:+447917128505) | [+91 77422 36474](tel:+917742236474)

Copyright © 2026 OSWAR ROTOCORP. All Rights Reserved. OSWAR® is a registered trademark of **OSWAR ROTOCORP**. This brochure makes no offers, representations or warranties (express or implied), and information and data contained in this brochure are for general reference only and may change at any time.